



ice line

MIGEL



SERIE
KF

FABBRICATORI DI GHIACCIO GRANULARE
MACHINES À GLACE EN GRAINS
ICE FLAKE MACHINES
FABRICADORES DE HIELO GRANULAR
EISFLOCKENBEREITER

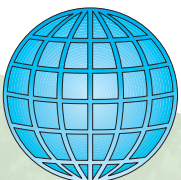

Fabbricatori di ghiaccio granulare serie KF



La gamma dei fabbricatori di ghiaccio granulare della serie KF è composta da 9 modelli con produzione giornaliera compresa tra i 42 Kg, 83 Kg, 141 Kg e i 183 Kg con contenitore incorporato; ed i modelli modulari da 205 Kg, 305 Kg, 615 Kg, 1.165 Kg e 2.330 Kg; fabbricatori modulari combinabili con i contenitori B/BL100, B/BL150, B/BL250 e TF60/RB60 o altri.

Il ghiaccio granulare della serie KF è ideale per l'uso nei bar, laboratori, ospedali, panifici, macellerie, pescherie, fast food e ristoranti. Un ghiaccio granulare con una temperatura ottimale (-0,5°C) asciutto, compatto e non tende ad impaccarsi.

Machines à glace en grains série KF



La gamme de machines à glace en grains série KF est composée par 9 modèles avec une production journalière comprise entre 42 Kg, 83 Kg, 141 Kg et 183 Kg, tous les trois avec le bac de conservation intégré; et les modèles modulaires de 205 Kg, 305 Kg, 615 Kg, 1.165 Kg et 2.330 Kg; machines à glace en grains modulaires pour combinaison avec les bacs de conservation B/BF100, B/BF150, B/BF250 et TF60/RB60 ou d'autres.

La glace en grains serie KF est idéale pour bar, laboratoires, hôpitaux, boulangeries, boucheries, poissonneries, Fast Food et restaurants. Une glace en grains avec une température idéale (-0,5°C), sèche, compacte qui ne s'empâte pas.

Ice flake machines series KF



The range of ice flake machines series KF consists of 9 models with a daily production between 42 Kg/92 Lb, 83 Kg/183 Lb, 141 Kg/310 Lb and 183 Kg/403 Lb all with built in storage bin; and the modular models 205 Kg/451 Lb, 305 Kg/671 Lb, 615 Kg/1.353 Lb 1.165 Kg/2.563 Lb; modular ice-flake machines to combine with the storage bin B/BF100, B/BF150, B/BF250 and TF60/RB60 or others.

The ice flake of series KF is ideal for bar, laboratories, hospitals, bakeries, butchers, fishmongers, Fast Food outlets and restaurants. An ice flake with a perfect temperature (-0,5°C) produced dry and compact.

Fabricadores de hielo granulador serie KF



La gama de fabricadores de hielo granulador serie KF está compuesta por 9 modelos con producción diaria comprendida entre 42 Kg, 83 Kg, 141 Kg y 183 Kg con depósito incorporado; y los modelos modulares de 205 Kg, 305 Kg, 615 Kg, 1.165 Kg y 2.330; modulares combinables con los depósitos B/BF100, B/BF150, B/BF250 y TF60/RB60.

El hielo granulador ideal para bar, laboratorios, hospitales, panificadores, carnicerías, pescaderías, Fast Food y restaurantes. El hielo granulador es seco, compacto, con tendencia a no comprimirse y con temperatura óptima (-0,5°C).

Eisflockenbereiter Serie KF



Die Produktgruppe der Eisflockenbereiter Serie KF besteht aus 9 Modellen mit Tagesleistungen von 42 Kg, 83 Kg, 141 Kg und 183 Kg, mit eingebautem Behälter; und den Modulen, 205 Kg, 305 Kg, 615 Kg, 1.165 Kg und 2.330 Kg, Bereiter im Modulbausystem kombinierbar mit den Behältern B/BF100, B/BF150, B/BF250 und TF60/RB60 oder anderen.

Die Eisflocke der Serie KF ist ideal für den Gebrauch in Bar, Laboratorien, Krankenhäusern, Bäckereien, Fleischereien, Fischhandel, Fast Food und Restaurants. Eine Eisflocke mit einer optimalen Temperatur (-0,5°C), trocken, kompakt und nicht matschig.

Caratteristiche Generali

- Produzione continua
- Controllo elettronico del funzionamento (modulari)
- Carrozzeria in acciaio inox (AISI 304)
- Raffreddamento ad aria (A) o ad acqua (W)
- KF85 con ventilazione frontale per l'incasso a richiesta (Mod. F)
- Interruttore generale (ON/OFF)
- Trasmissione a cinghia
- Costi di esercizio ridotti, consumi di elettricità ed acqua bassi
- Ingombro ridotto
- Massima accessibilità alla componentistica
- Refrigerante R404A

Caractéristiques Générales

- Production continue
- Contrôle électronique du fonctionnement (modulaires)
- Carrosserie en acier inoxydable (AISI 304)
- Refroidissement par air (A) ou par eau (W)
- KF85 avec ventilation frontale pour encastrement (Mod. F)
- Interrupteur général (ON/OFF)
- Transmission par courroie
- Réduits coûts d'exercice, réduite consommation d'électricité et d'eau
- Dimensions réduites
- Composants facilement accessibles
- Réfrigérant R404A

General Specifications

- Continuous production
- Electronic function control (modular flakers)
- Stainless steel bodywork (BS 304 S01)
- Condensing units air cooled (A) or water cooled (W)
- KF85 with frontal ventilation for boxing in (Mod. F)
- Main switch (ON/OFF)
- Belt drive system
- Low power and water consumption
- Reduced dimensions
- Maximum accessibility to components
- Refrigerant R404A

Características Generales

- Producción continua
- Controles electrónicos de funcionamiento (modulares)
- Carrocería en acero inoxidable (AISI 304)
- Condensación por aire (A) o por agua (W)
- KF85 con ventilación frontal bajo barra (Mod. F)
- Interruptor general (ON/OFF)
- Transmisión por correa
- Reducido coste de fabricación, consumos eléctricos y de agua bajos
- Dimensiones reducidas
- Máxima accesibilidad sobre lo componentes
- Refrigerante R404A

Generelle Eigenschaften

- Kontinuierliche Eisproduktion
- Elektronische Steuerung (Module)
- Chromnickelstahl Gehäuse (AISI 304)
- Luftkühlung (A) oder Wasserkühlung (W)
- KF85 mit Frontbelüftung für den Einbau auf Anfrage (Mod. F)
- Hauptschalter (Ein/Aus)
- Keilriemenantrieb
- Reduzierte Betriebskosten durch eingeschränkten Strom- und Wasserverbrauch
- Reduzierte Ausmaße
- Leicht erreichbare Komponenten
- Kältemittel R404A

MIGEL KF

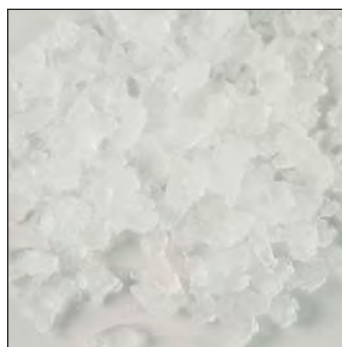
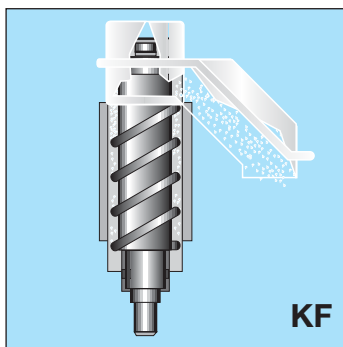

FILTER
a richiesta
sur demande
on request
a petición
auf Anfrage



a richiesta • sur demande • on request
a petición • auf Anfrage

Attenzione:

Le produzioni nelle 24h si intendono ad una temperatura ambiente +10°C e una temperatura acqua +10°C. Il voltaggio standard è V230/50Hz monofase. Altri voltaggi come V230/60Hz e V115/60Hz monofase a richiesta. I modelli e le caratteristiche possono subire modifiche senza preavviso.

Attention:

Les productions dans les 24 heures s'entendent à une température ambiante de +10°C et à une température de l'eau de +10°C. Le voltage standard est de 230V/50Hz monophasé. Sur demande, possibilité de fourniture d'autres voltages comme le 230V/50Hz et le 115V/60Hz monophasé. Les modèles et les caractéristiques peuvent subir des modifications sans préavis.

Important:

24h production is intended at an ambient temperature of +10°C with a water temperature of +10°C. Standard voltage is V230/50Hz single phase. Other voltages such as V230/60Hz and V115/60Hz single phase on request. Models and specifications may be subject to variations without prior notice.

Atención:

Las producciones en las 24h se consideran con una temperatura ambiente de +10°C y una temperatura del agua de +10°C. El voltaje estándar es V230/50Hz monofásico. Otros voltajes como V230/60Hz y V115/60Hz monofásico a petición. Los modelos y las características pueden sufrir variaciones sin aviso previo.

Achtung:

Die Produktion innerhalb von 24 Stunden versteht sich bei einer Raumtemperatur von +10°C sowie einer Wassertemperatur von +10°C. Die Standardspannung beträgt V230/50Hz einphasig. Weitere Spannungswerte wie V230/60Hz und V115/60 Hz einphasig auf Anfrage. Die Modelle und Charakteristiken können Änderungen ohne Vorankündigung unterliegen.



KF 45

	A	W
Produzione • Production • Production Produccion • Tagesleistung	*Kg/24h Lb/24h	40 42 88 92
Capacità contenitore • Capacité bac • Bin capacity Capacidad del deposito • Behälterkapazität	Kg - Lb	10 - 22
Assorbimento • Consommation • Power Potencia • Leistungsaufnahme	(T=43°C)-W	410
Peso netto • Poids net • Net weight Peso neto • Nettogewicht	Kg	39
Peso lordo • Poids brut • Gross weight Peso bruto • Bruttogewicht	Kg	41
Volume con imballo • Volume emballage Volume packing • Volume con embalage Verpackungsvolumen	m ³	0,16
Refrigerante • Réfrigérant • Refrigerant Refrigerante • Kältemittel		R404A
Voltaggio standard • Voltage standard • Standard voltage Voltaje • Anschlußspannung		V230/50Hz/1

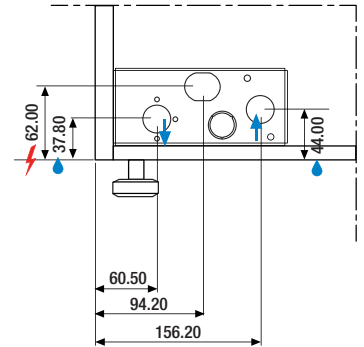

KF 85

	A	W
Produzione • Production • Production Produccion • Tagesleistung	*Kg/24h Lb/24h	80 83 176 183
Capacità contenitore • Capacité bac • Bin capacity Capacidad del deposito • Behälterkapazität	Kg - Lb	25 - 55
Assorbimento • Consommation • Power Potencia • Leistungsaufnahme	(T=43°C)-W	520
Peso netto • Poids net • Net weight Peso neto • Nettogewicht	Kg	55
Peso lordo • Poids brut • Gross weight Peso bruto • Bruttogewicht	Kg	59
Volume con imballo • Volume emballage Volume packing • Volume con embalage Verpackungsvolumen	m ³	0,30
Refrigerante • Réfrigérant • Refrigerant Refrigerante • Kältemittel		R404A
Voltaggio standard • Voltage standard • Standard voltage Voltaje • Anschlußspannung		V230/50Hz/1

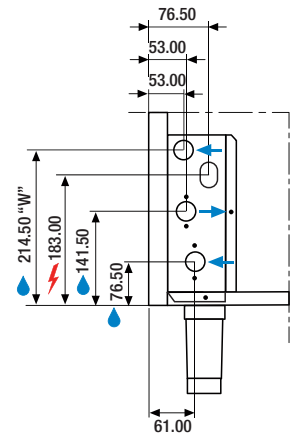

KF 145

	A	W
Produzione • Production • Production Produccion • Tagesleistung	*Kg/24h Lb/24h	135 141 297 310
Capacità contenitore • Capacité bac • Bin capacity Capacidad del deposito • Behälterkapazität	Kg - Lb	42 - 92
Assorbimento • Consommation • Power Potencia • Leistungsaufnahme	(T=43°C)-W	590
Peso netto • Poids net • Net weight Peso neto • Nettogewicht	Kg	69
Peso lordo • Poids brut • Gross weight Peso bruto • Bruttogewicht	Kg	76
Volume con imballo • Volume emballage Volume packing • Volume con embalage Verpackungsvolumen	m ³	0,49
Refrigerante • Réfrigérant • Refrigerant Refrigerante • Kältemittel		R404A
Voltaggio standard • Voltage standard • Standard voltage Voltaje • Anschlußspannung		V230/50Hz/1

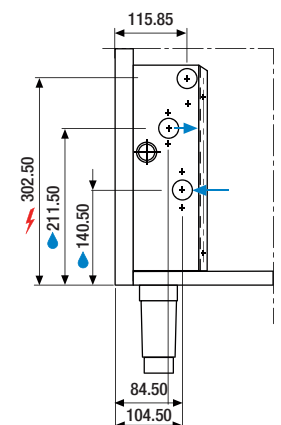



KF 185

	A	W
Produzione • Production • Production Produccion • Tagesleistung	*Kg/24h Lb/24h	175 183 385 403
Capacità contenitore • Capacité bac • Bin capacity Capacidad del deposito • Behälterkapazität	Kg - Lb	60 - 132
Assorbimento • Consommation • Power Potencia • Leistungsaufnahme	(T=43°C)-W	650
Peso netto • Poids net • Net weight Peso neto • Nettogewicht	Kg	85
Peso lordo • Poids brut • Gross weight Peso bruto • Bruttogewicht	Kg	89
Volume con imballo • Volume emballage Volume packing • Volume con embalage Verpackungsvolumen	m ³	0,63
Refrigerante • Réfrigérant • Refrigerant Refrigerante • Kältemittel		R404A
Voltaggio standard • Voltage standard • Standard voltage Voltaje • Anschlußspannung		V230/50Hz/1

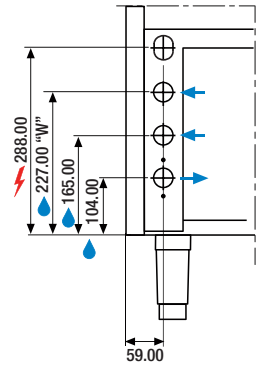

KF 200

	A	W
Produzione • Production • Production Produccion • Tagesleistung	*Kg/24h Lb/24h	195 205 429 451
Capacità contenitore • Capacité bac • Bin capacity Capacidad del deposito • Behälterkapazität	Kg - Lb	-
Assorbimento • Consommation • Power Potencia • Leistungsaufnahme	(T=43°C)-W	800
Peso netto • Poids net • Net weight Peso neto • Nettogewicht	Kg	58
Peso lordo • Poids brut • Gross weight Peso bruto • Bruttogewicht	Kg	63
Volume con imballo • Volume emballage Volume packing • Volume con embalage Verpackungsvolumen	m ³	0,30
Refrigerante • Réfrigérant • Refrigerant Refrigerante • Kältemittel		R404A
Voltaggio standard • Voltage standard • Standard voltage Voltaje • Anschlußspannung		V230/50Hz/1

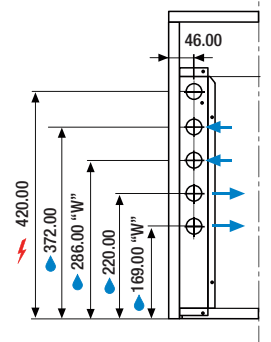

KF 300

	A	W
Produzione • Production • Production Produccion • Tagesleistung	*Kg/24h Lb/24h	300 305 660 671
Capacità contenitore • Capacité bac • Bin capacity Capacidad del deposito • Behälterkapazität	Kg - Lb	-
Assorbimento • Consommation • Power Potencia • Leistungsaufnahme	(T=43°C)-W	1150
Peso netto • Poids net • Net weight Peso neto • Nettogewicht	Kg	58
Peso lordo • Poids brut • Gross weight Peso bruto • Bruttogewicht	Kg	63
Volume con imballo • Volume emballage Volume packing • Volume con embalage Verpackungsvolumen	m ³	0,30
Refrigerante • Réfrigérant • Refrigerant Refrigerante • Kältemittel		R404A
Voltaggio standard • Voltage standard • Standard voltage Voltaje • Anschlußspannung		V230/50Hz/1

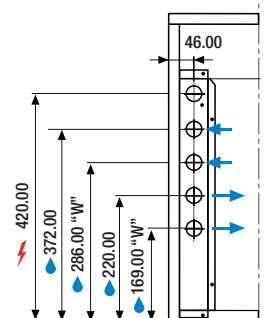



KF 600

	A	W
Produzione • Production • Production Produccion • Tagesleistung	*Kg/24h Lb/24h	600 615 1320 1353
Capacità contenitore • Capacité bac • Bin capacity Capacidad del deposito • Behälterkapazität	Kg - Lb	-
Assorbimento • Consommation • Power Potencia • Leistungsaufnahme	(T=43°C)-W	1950
Peso netto • Poids net • Net weight Peso neto • Nettogewicht	Kg	111
Peso lordo • Poids brut • Gross weight Peso bruto • Bruttogewicht	Kg	115
Volume con imballo • Volume emballage Volume packing • Volume con embalage Verpackungsvolumen	m ³	0,48
Refrigerante • Réfrigérant • Refrigerant Refrigerante • Kältemittel		R404A
Voltaggio standard • Voltage standard • Standard voltage Voltaje • Anschlußspannung		V230/50Hz/1

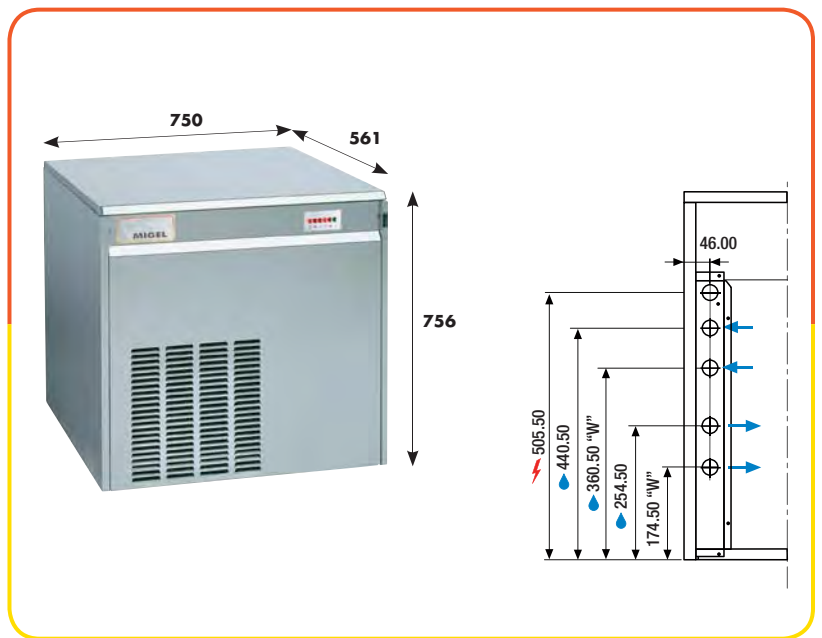

KF 1200

	A	W
Produzione • Production • Production Produccion • Tagesleistung	*Kg/24h Lb/24h	1150 1165 2530 2563
Capacità contenitore • Capacité bac • Bin capacity Capacidad del deposito • Behälterkapazität	Kg - Lb	-
Assorbimento • Consommation • Power Potencia • Leistungsaufnahme	(T=43°C)-W	3600
Peso netto • Poids net • Net weight Peso neto • Nettogewicht	Kg	173
Peso lordo • Poids brut • Gross weight Peso bruto • Bruttogewicht	Kg	190
Volume con imballo • Volume emballage Volume packing • Volume con embalage Verpackungsvolumen	m ³	0,76
Refrigerante • Réfrigérant • Refrigerant Refrigerante • Kältemittel		R404A
Voltaggio standard • Voltage standard • Standard voltage Voltaje • Anschlußspannung		V230/50Hz/1

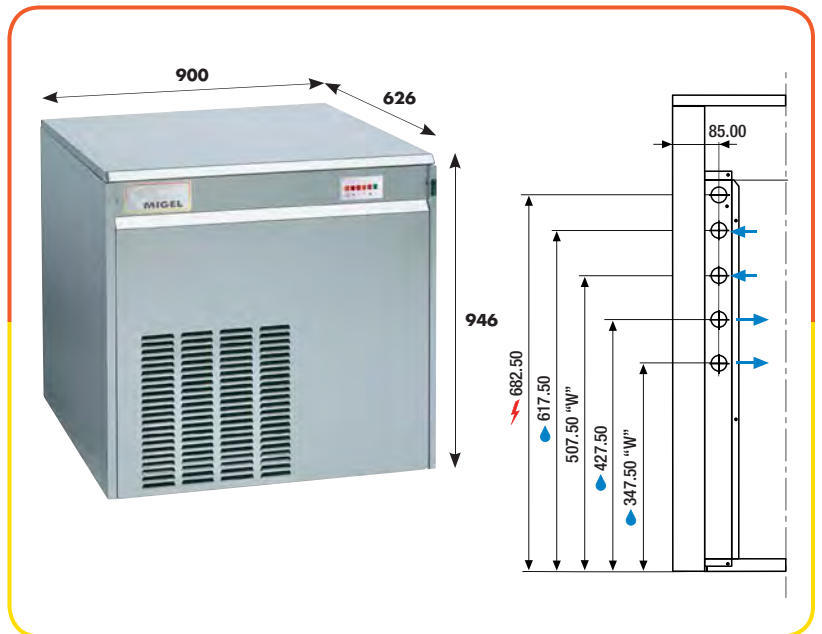

KF 2500

	A	W
Produzione • Production • Production Produccion • Tagesleistung	*Kg/24h Lb/24h	2300 2330 5060 5126
Capacità contenitore • Capacité bac • Bin capacity Capacidad del deposito • Behälterkapazität	Kg - Lb	-
Assorbimento • Consommation • Power Potencia • Leistungsaufnahme	(T=43°C)-W	2x3600
Peso netto • Poids net • Net weight Peso neto • Nettogewicht	Kg	295
Peso lordo • Poids brut • Gross weight Peso bruto • Bruttogewicht	Kg	318
Volume con imballo • Volume emballage Volume packing • Volume con embalage Verpackungsvolumen	m ³	1,40
Refrigerante • Réfrigérant • Refrigerant Refrigerante • Kältemittel		R404A
Voltaggio standard • Voltage standard • Standard voltage Voltaje • Anschlußspannung		V230/50Hz/1

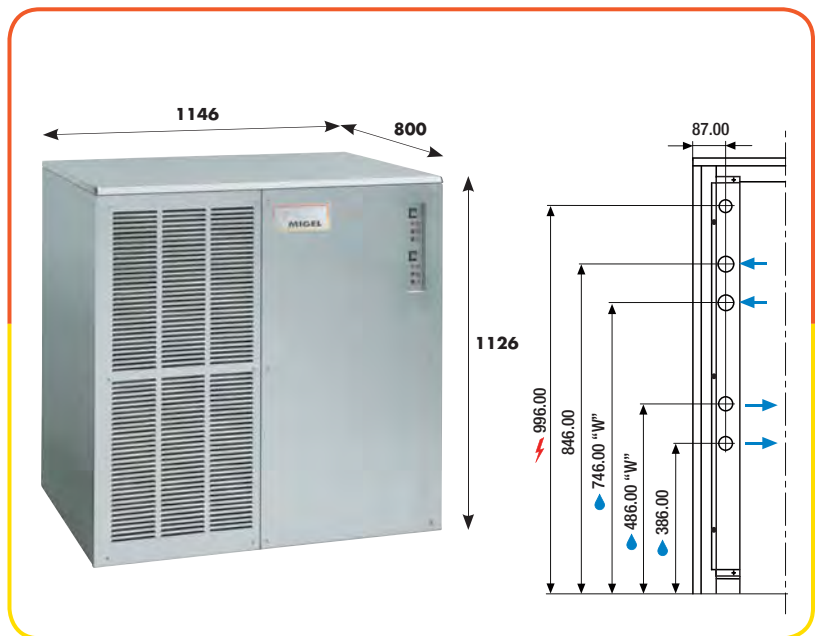



TF 60/RB 60

	A	W
Capacità contenitore • Capacité bac • Bin capacity Capacidad del deposito • Behälterkapazität	Kg - Lb	60 - 132
Peso netto • Poids net • Net weight Peso neto • Nettogewicht	Kg	47
Peso lordo • Poids brut • Gross weight Peso bruto • Bruttogewicht	Kg	51
Volume con imballo • Volume emballage Volume packing • Volume con embalage Verpackungsvolumen	m ³	0,54

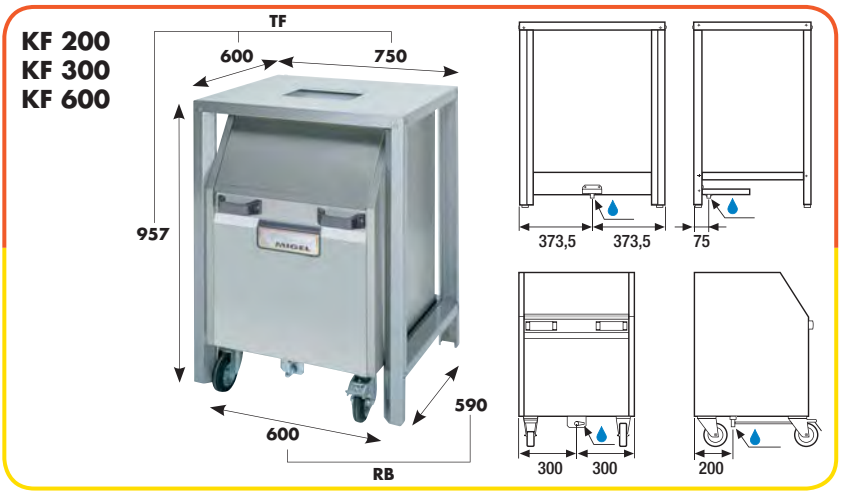

B 100/BF 100

	A	W
Capacità contenitore • Capacité bac • Bin capacity Capacidad del deposito • Behälterkapazität	Kg - Lb	100 - 220
Peso netto • Poids net • Net weight Peso neto • Nettogewicht	Kg	31
Peso lordo • Poids brut • Gross weight Peso bruto • Bruttogewicht	Kg	38
Volume con imballo • Volume emballage Volume packing • Volume con embalage Verpackungsvolumen	m ³	0,54

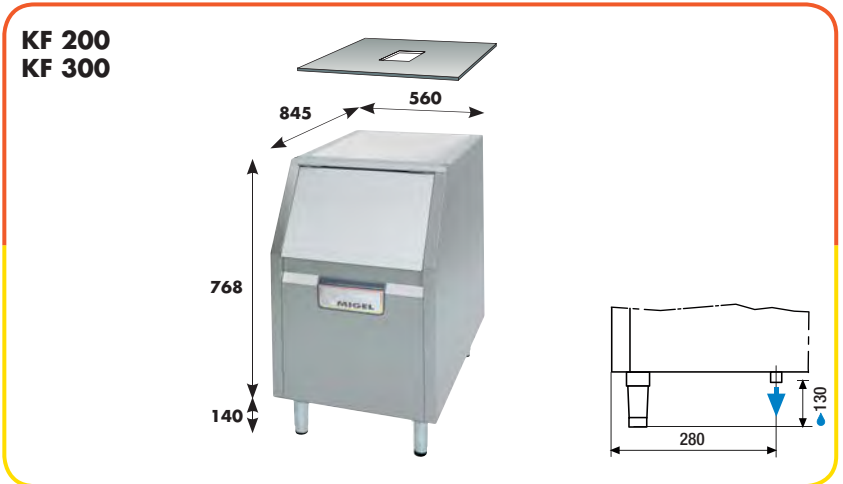

B 150/BF 150

	A	W
Capacità contenitore • Capacité bac • Bin capacity Capacidad del deposito • Behälterkapazität	Kg - Lb	150 - 330
Peso netto • Poids net • Net weight Peso neto • Nettogewicht	Kg	49
Peso lordo • Poids brut • Gross weight Peso bruto • Bruttogewicht	Kg	55
Volume con imballo • Volume emballage Volume packing • Volume con embalage Verpackungsvolumen	m ³	0,90

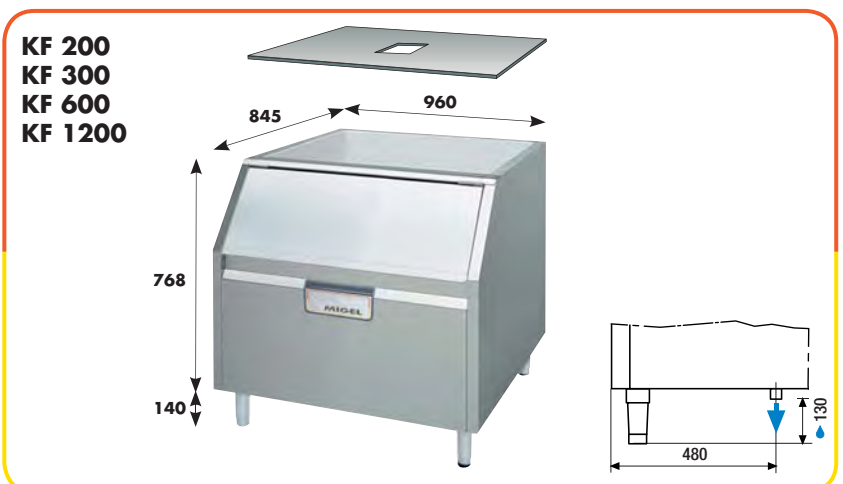

B 250/BF 250

	A	W
Capacità contenitore • Capacité bac • Bin capacity Capacidad del deposito • Behälterkapazität	Kg - Lb	250 - 550
Peso netto • Poids net • Net weight Peso neto • Nettogewicht	Kg	62
Peso lordo • Poids brut • Gross weight Peso bruto • Bruttogewicht	Kg	68
Volume con imballo • Volume emballage Volume packing • Volume con embalage Verpackungsvolumen	m ³	1,09

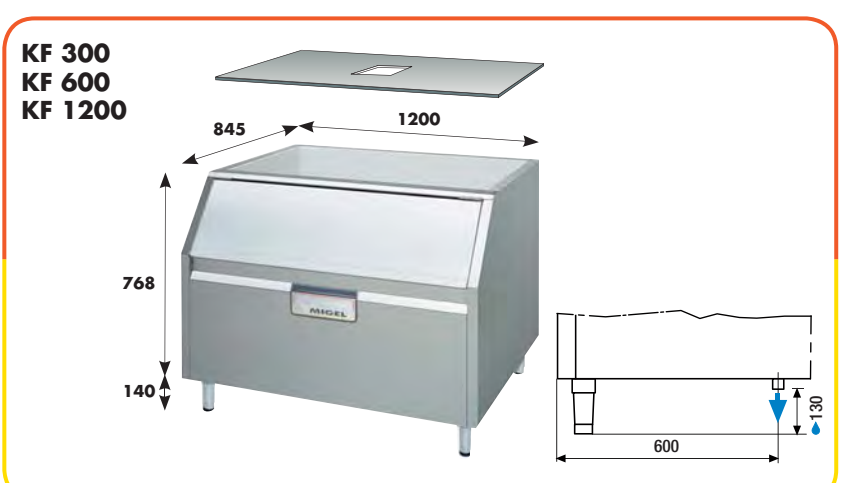

**KF 200
KF 300
KF 600**

**KF 200
KF 300
KF 600
KF 1200**

**KF 300
KF 600
KF 1200**



Migel S.r.l. Viale Risorgimento, 28 - I - 20030 Senago (MI)
Tel. (+39) 02 99057727 - Fax (+39) 02 99056470 - e-mail: migel@migel-ice-line.com
www.migel-ice-line.com

